

FMS

Flexible Manufacturing System

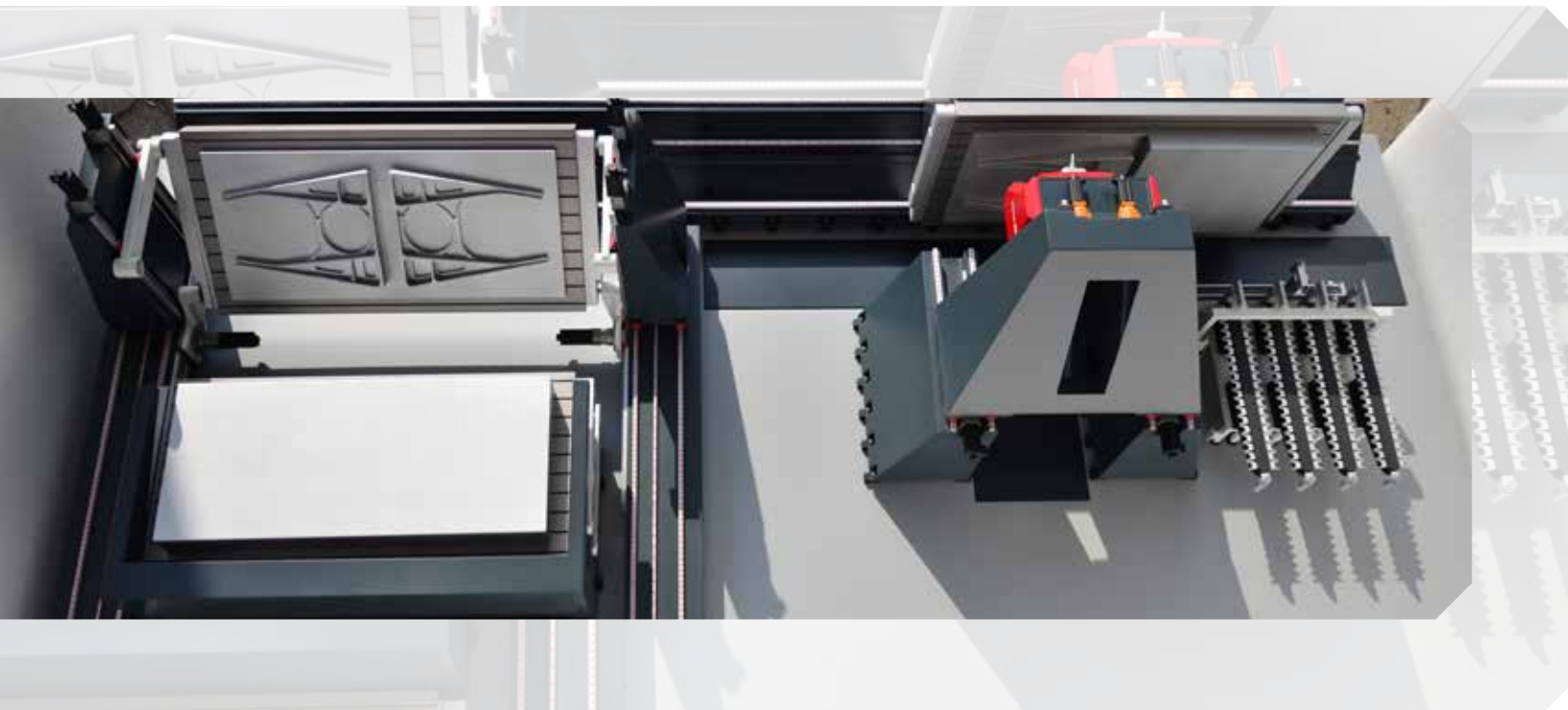

FIDIA 



The new FMS system designed by Fidia is equipped with a sophisticated software that optimizes and enhances its operative characteristics. This system is Fidia's answer to the more pressing request to increasing the level of workshop automation and integrates a powerful and versatile pallet system.

The FMS platform serves independent working cells and allows for the complete machining of complex components in 3 or 5 axes, starting from the rough part.

This system is the ideal solution for a highly developed workshop environment, requiring the best standards of automation levels.

The powerful dedicated software automatically manages and optimizes production flow without intervention of the machine operator. Such functionality achieves the following goals:

- Reduction of waiting times;
- Simplification of programming;
- Optimization of tool wear-out;
- Full monitoring of production flow;
- Reduction of human error risks;
- Never-ending 7/7 and 24/24 production.

Each machine can also be operated independently, allowing the normal functioning of the FMS system with the other machines.



FMS configuration

- G996 machine for roughing out.
- 2 G996 machines for finishing.
- 1 automatic pallet changer.
- 1 manual loading/unloading station.
- 4 stacking stations.
- 6 pallets.
- Pallet capacity 2000 kg (4409 lbs).
- Total length of installed system 17 m (670").

The system can also work in unmanned machining mode.



G996

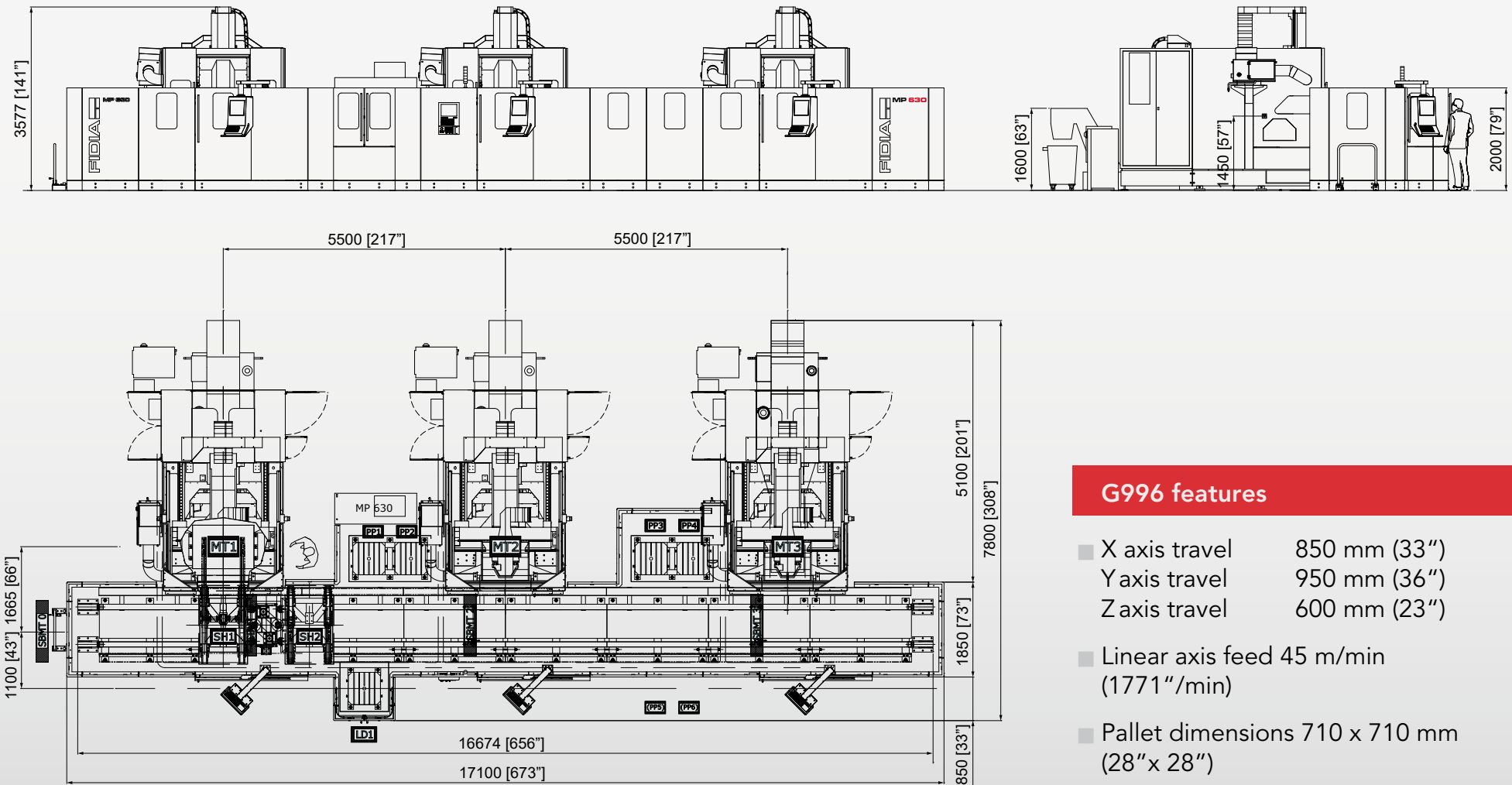

G996 features

- X axis travel 850 mm (33")
- Y axis travel 950 mm (36")
- Z axis travel 600 mm (23")
- Linear axis feed 45 m/min (1771"/min)
- Pallet dimensions 710 x 710 mm (28"x 28")
- Spindle 30kW - 24000 1/min - HSK-A63

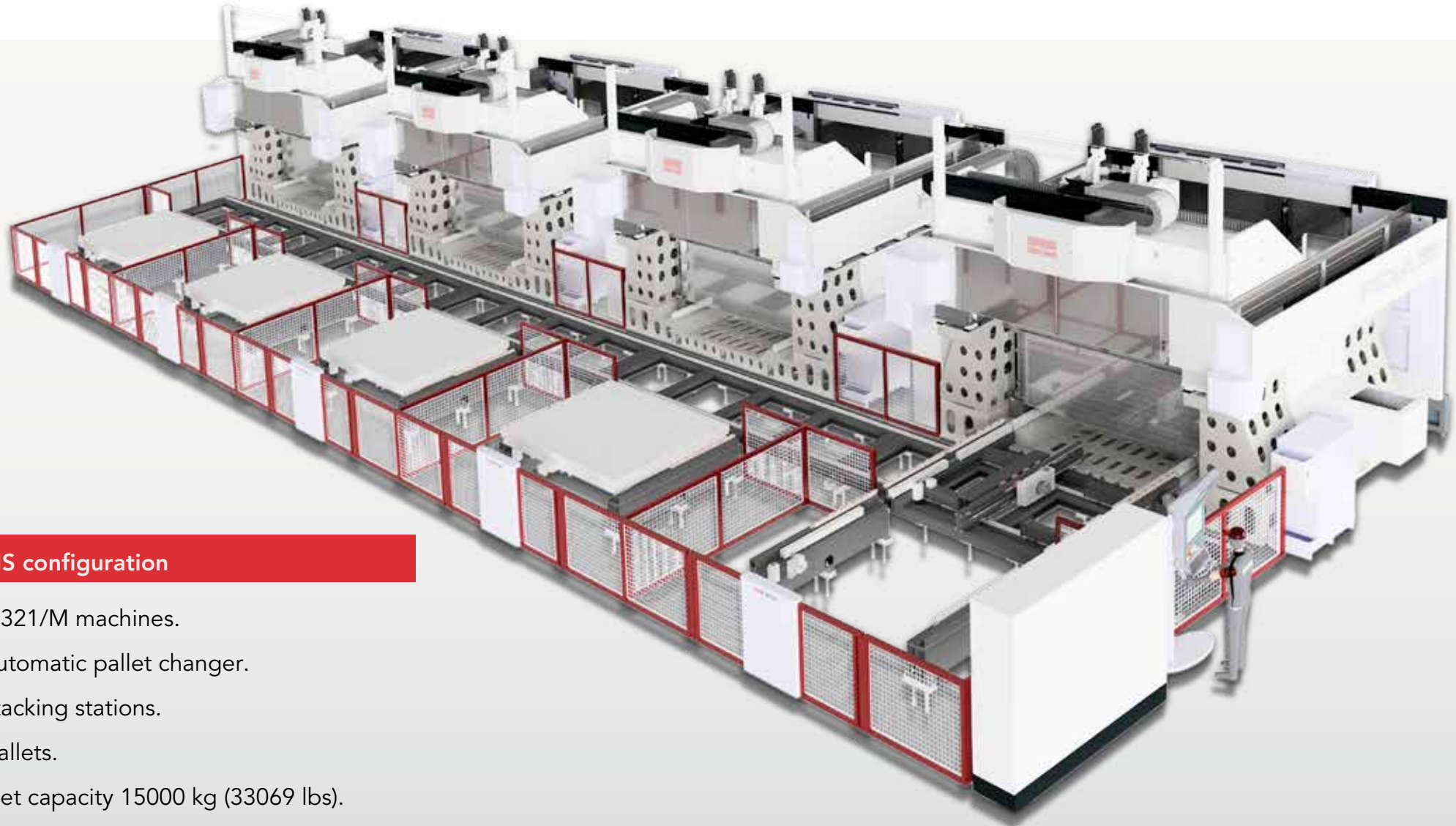

FMS configuration

- 4 D321/M machines.
- 1 automatic pallet changer.
- 5 stacking stations.
- 8 pallets.
- Pallet capacity 15000 kg (33069 lbs).
- Total length of installed system 32 m (1260").

D321/M

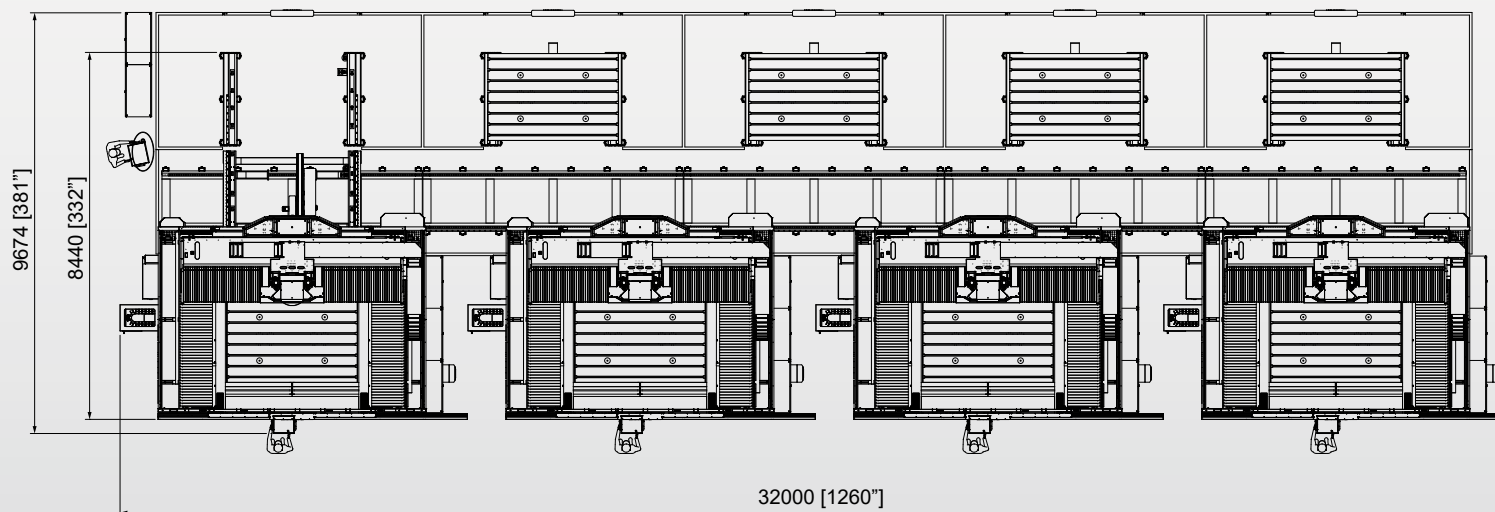
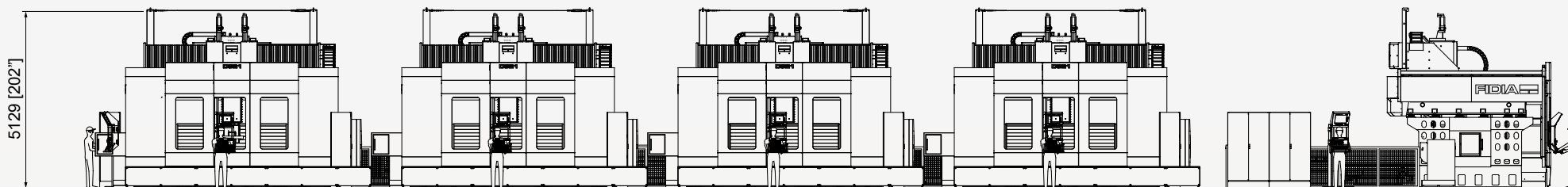

D321/M features

- X axis travel 3000 mm (118")
- Y axis travel 2200 mm (86")
- Z axis travel 1100 mm (43")
- Linear axis feed 24 m/min (994"/min)
- Pallet dimensions 3000 x 2000 mm (118"x 78")
- Spindle 55kW - 24000 1/min - HSK63A
- A axis +95° / -110°
- C axis +/- 360°

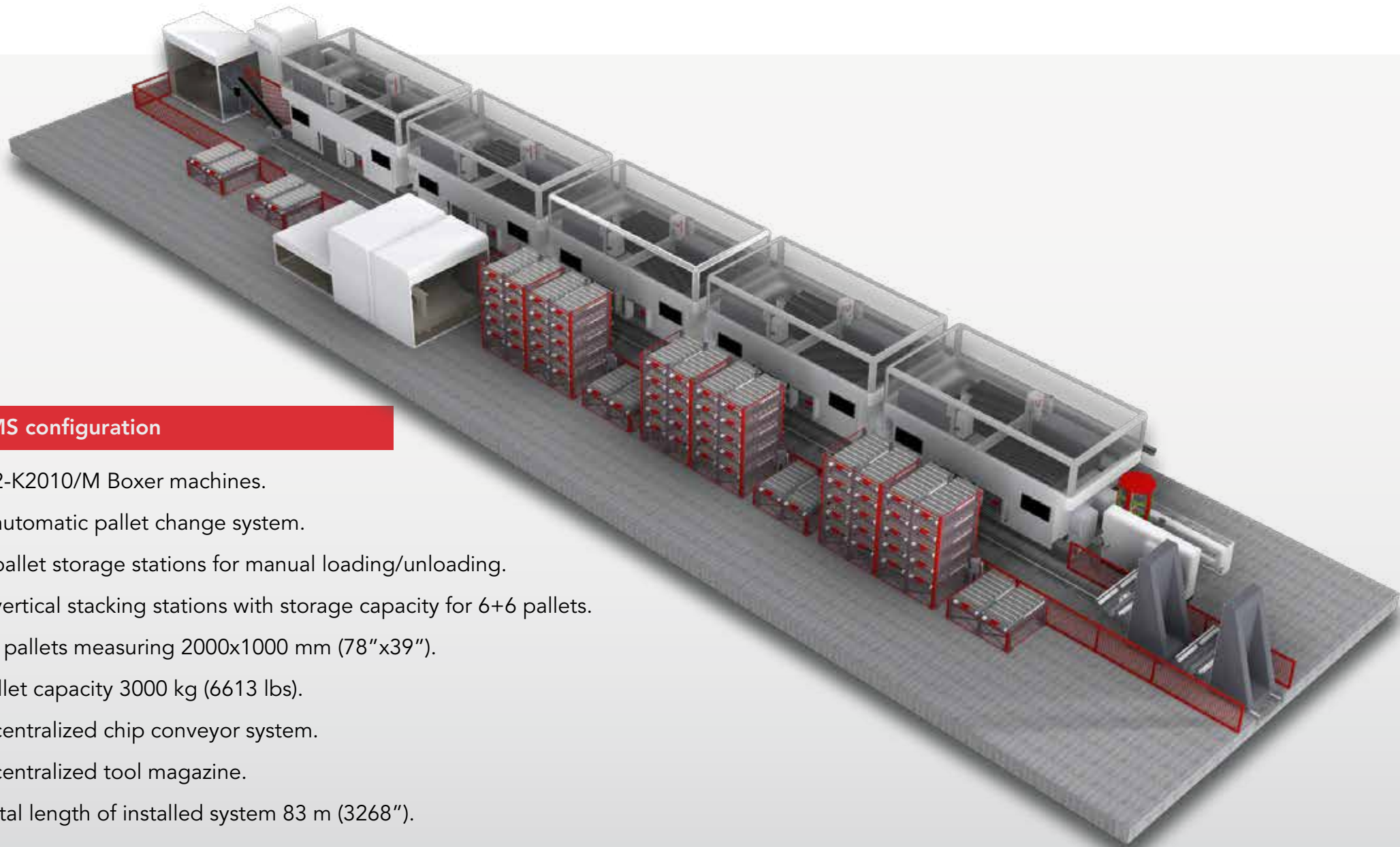

FMS configuration

- 5 2-K2010/M Boxer machines.
- 1 automatic pallet change system.
- 5 pallet storage stations for manual loading/unloading.
- 5 vertical stacking stations with storage capacity for 6+6 pallets.
- 60 pallets measuring 2000x1000 mm (78"x39").
- Pallet capacity 3000 kg (6613 lbs).
- 1 centralized chip conveyor system.
- 1 centralized tool magazine.
- Total length of installed system 83 m (3268").

K2010

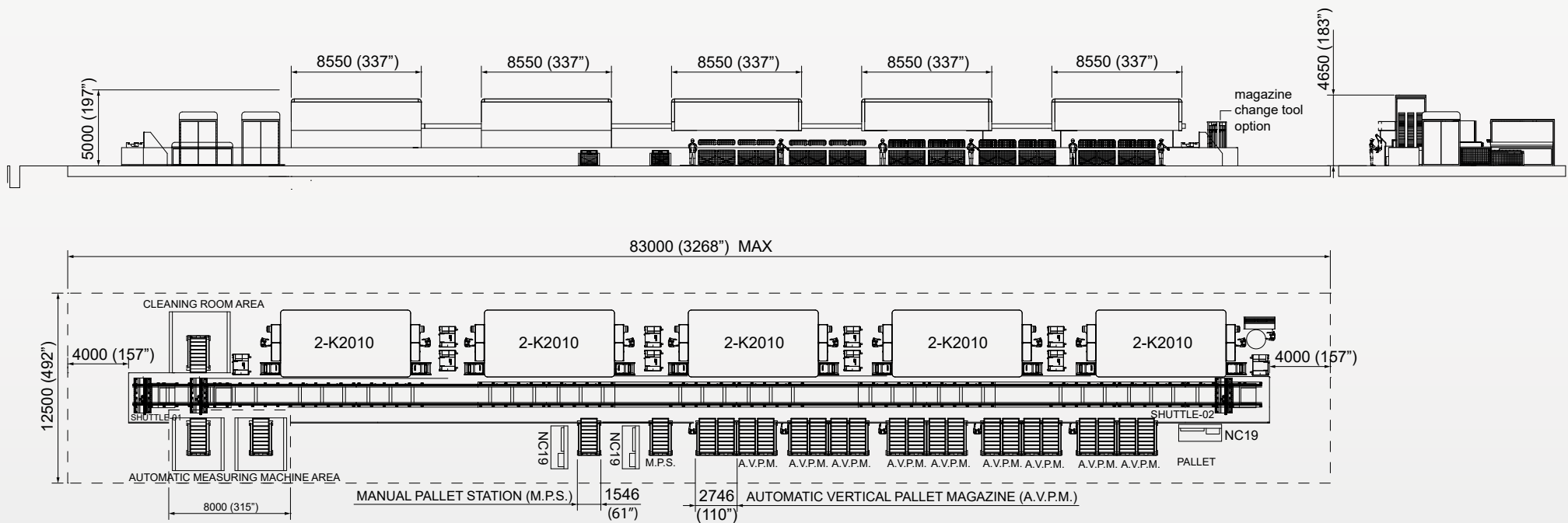

K2010/M features

Each side:

- X axis travel 2000 mm (39")
- Y axis travel 1000 mm (39")
- Z axis travel 600 mm (39")
- Linear axis feed 24 m/min (39"/min)
- Spindle 55kW - 24000 1/min - HSK63A
- A axis +95° / -110°
- C axis +/- 360°

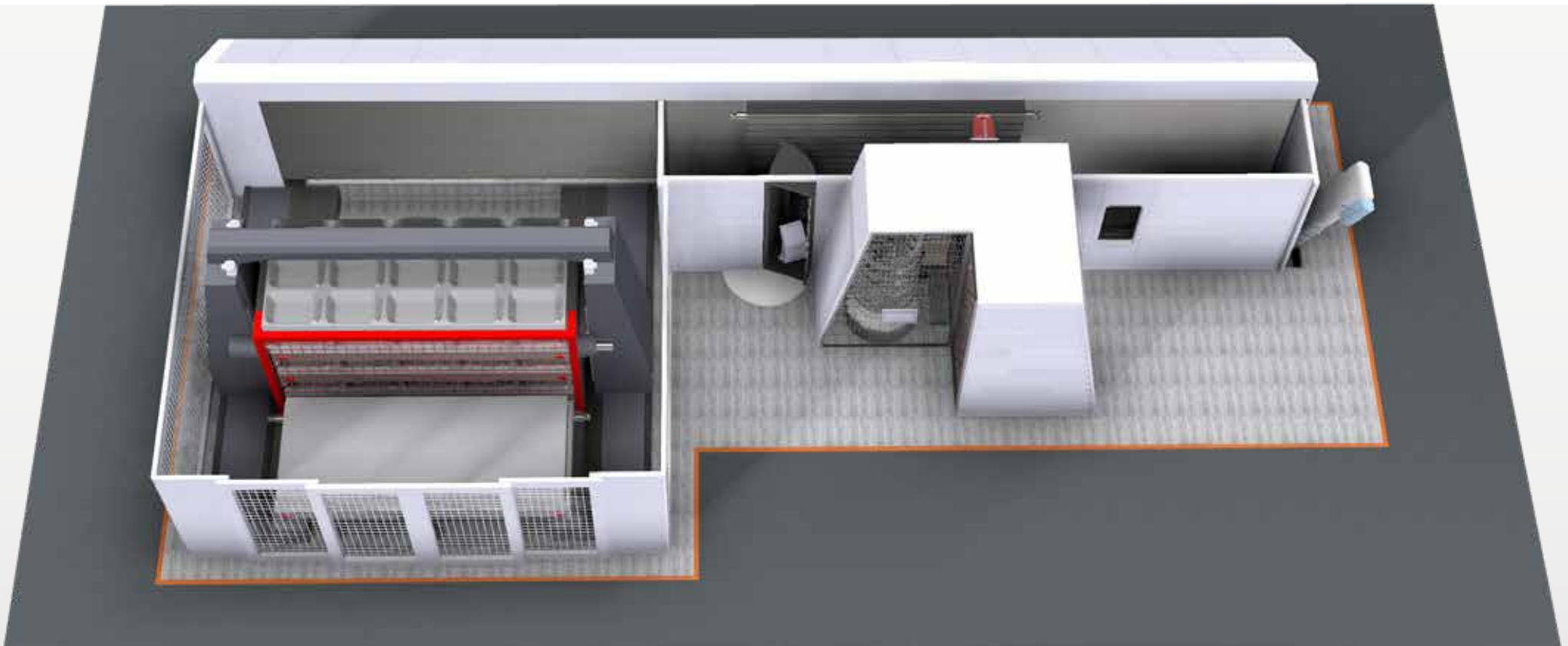

FMS configuration

- 1 HTF/T machine.
- 1 automatic pallet changer.
- 1 loading/unloading station.
- 4 stacking stations.
- 6 pallets.
- Pallet capacity 6000 kg (132278 lbs).
- Total length of installed system 26 m (1023").

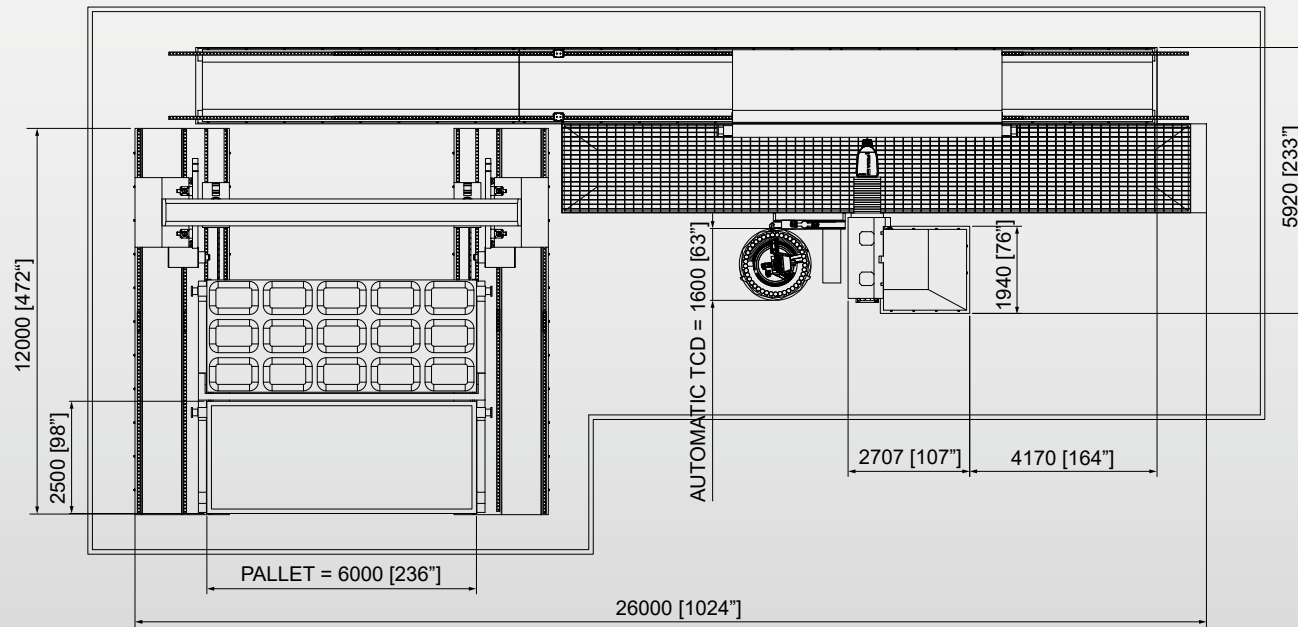
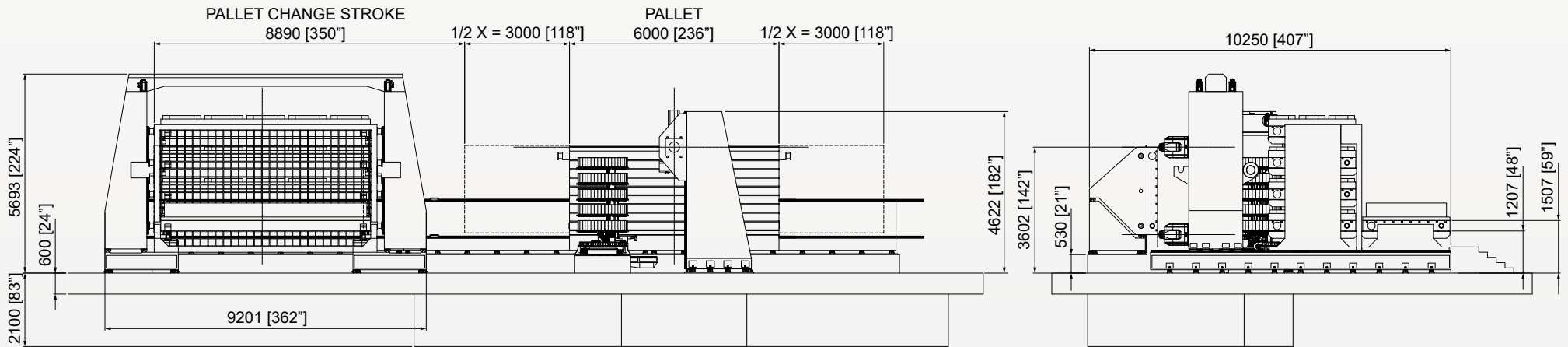

Fidia Horizontal Type features

- X axis travel 4000 mm (157")
- Y axis travel 2000 / 2500 mm (78"/98")
- Z axis travel 1000 mm (39")
- Linear axis feed 25 m/min (984"/min)
- Spindle 55kW - 6000 1/min - HSK-A100
- A axis + 60 /- 90°
- C axis +/- 40°



FIDIA S.p.A.
Corso Lombardia, 11
10099 San Mauro Torinese - TO - ITALY
Tel. +39 011 2227111
Fax +39 011 2238202
info@fidia.it
www.fidia.com

FIDIA GmbH
Robert-Bosch-Strasse 18
63303 Dreieich-Sprendlingen - GERMANY
Tel. +49 6103 4858700
Fax +49 6103 4858777
info@fidia.de

FIDIA Co.
3098 Research Drive
Rochester Hills MI 48309 - USA
Tel. +1 248 6800700
Fax +1 248 6800135
info@fidia.com

FIDIA Sarl
47 bis, Avenue de l'Europe
B.P. 3 - Emerainville
77313 Marne La Vallée Cedex 2 - FRANCE
Tel. +33 1 64616824
Fax +33 1 64616794
info@fidia.fr

FIDIA Iberica S.A.
Parque Tecnológico
Laida Bidea, Edificio 208
48170 Zamudio - Bizkaia - SPAIN
Tel. +34 94 4209820
Fax +34 94 4209825
info@fidia.es

FIDIA DO BRASIL LTDA
Av. Padre Anchieta, 161 - Jordanopolis
São Bernardo do Campo
09891-420 - SP - BRASIL
Tel. +55 11 3996-2925
info@fidia.com.br

FIDIA JVE
Beijing Fidia Machinery & Electronics Co., Ltd
Room 1509, 15/F Tower A. TYG Center Mansion
C2 North Road East Third Ring Road,
Chaoyang District - 100027 BEIJING - P.R. CHINA
Tel. +86 10 64605813/4/5
Fax +86 10 64605812
info@fidia.com.cn

FIDIA JVE
Shanghai Office
28/D, No.1076, Jiangning Road
Putuo District - Shanghai 200060 - CHINA
Tel. +86 21 52521635
Fax +86 21 62760873
shanghai@fidia.com.cn

OOO FIDIA
c/o Promvost
Sushovskiy Val, Dom 5, Str. 2, Office 411
127018 Moscow - RUSSIA
Tel.: +7 499 9730461
Mobile: +7 9035242669
sales.ru@fidia.it
service.ru@fidia.it

Service centres:

FIDIA GmbH - SERVICE CZ
CZ- 74706 Opava
Tel/Fax +420 553 654 402
sales.cz@fidia.it

FIDIA S.p.A. - SALES & SERVICE UK
32 Riverside, Riverside Place
Cambridge - Cambridgeshire
CB5 8JF - United Kingdom
Mobile: +44 - (0)7425 838162
sales.uk@fidia.it

3H MAKINA
Atasehir Bulvari, Ata 2/3
Plaza, Kat: 9 No: 80
Atasehir - Istanbul - TURKEY
Tel.: +90 216 456 10 43
Fax: +90 216 456 75 23
sales.tr@fidia.it
service.tr@fidia.it

AXIS SYSTEMS
T8 ~ T9 ~ T20, "INSPIRIA"
Old Mumbai - Pune Highway,
Pune - 411044, India
Cell : +91 9881245460
service.in@fidia.it

P.V. ELECTRONIC SERVICES C.C.
P.O. Box 96
Hunters Retreat 6017
Port Elisabeth SOUTH AFRICA
Tel. +27 41 3715143
Fax +27 41 3715143
sales.za@fidia.it

SHIYAN FIDIA SERVICE CENTRE
N.84 Dong Yue Road,
Shiyan, Hubei - CHINA
Tel. +86 719 8225781
Fax +86 719 8228241

CHENGDU FIDIA SERVICE CENTRE
Huang Tian Ba
Chengdu, Sichuan - CHINA
Tel. +86 28 87406091
Fax +86 28 87406091

IE-MAT s.r.l.
Bv. De Los Calabreses 3706
Barrio: Boulevares.
Córdoba - ARGENTINA
CP: X5022EWWW
Tel. +54 351 5891717
sales.ar@fidia.it

Manufacturing plants:

FIDIA S.p.A.
Via Valpellece, 67/A
10060 San Secondo di Pinerolo
TO - ITALY
Tel. +39 0121 500676
Fax +39 0121 501273

FIDIA S.p.A.
Via Balzella, 76
47100 Forlì
ITALY
Tel. +39 0543 770511
Fax +39 0543 795573
info@fidia.it

SHENYANG FIDIA NC & MACHINE CO., LTD.
No. 1 17 Jia Kaifa Rd.
Shenyang Economic & Technological Development Zone
110141 Shenyang - P.R. CHINA
Tel. +86 24 25191218/9
Fax +86 24 25191217
info@fidia.com.cn

Research centres:

FIDIA S.p.A.
c/o Tecnopolis
Str. Provinciale per Casamassima Km 3,
70010 Valenzano
Bari - ITALY
Tel. +39 080 4673862

